



(19) **United States**

(12) **Patent Application Publication**  
**Johnson et al.**

(10) **Pub. No.: US 2003/0002160 A1**

(43) **Pub. Date: Jan. 2, 2003**

(54) **LENTICULAR LENS ARRAY AND TOOL FOR MAKING A LENTICULAR LENS ARRAY**

**Publication Classification**

(75) Inventors: **Ralph Barry Johnson**, Huntsville, AL (US); **Gary A. Jacobsen**, Itasca, IL (US)

(51) **Int. Cl.<sup>7</sup>** ..... **G02B 27/10**  
(52) **U.S. Cl.** ..... **359/619**

Correspondence Address:  
**KING & SPALDING**  
**191 PEACHTREE STREET, N.E.**  
**ATLANTA, GA 30303-1763 (US)**

(57) **ABSTRACT**

(73) Assignee: **Web Communications Group, Inc.**, Itasca, IL

A lenticular lens array for creating a visual effect for an image viewed through the lenticular lens array comprises a plurality of lenticules disposed adjacent to each other. Each lenticule comprises a lenticular lens element on one side and a substantially flat surface on an opposite side. Each lenticular lens element has a vertex and a cross section comprising a portion of an elliptical shape. Alternatively, the cross section can comprise an approximated portion of an elliptical shape. The elliptical shape comprises a major axis disposed substantially perpendicular to the substantially flat surface of each respective lenticular lens element. The vertex of each respective lenticular lens element lies substantially along the major axis of the elliptical shape.

(21) Appl. No.: **10/167,020**

(22) Filed: **Jun. 10, 2002**

**Related U.S. Application Data**

(60) Provisional application No. 60/297,148, filed on Jun. 8, 2001.

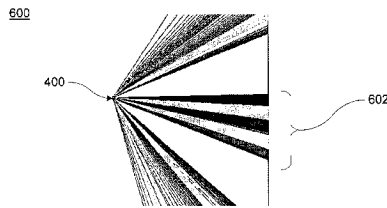
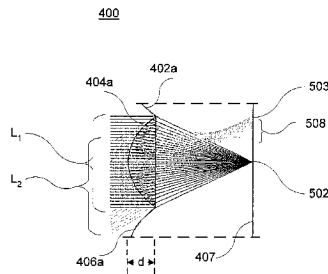
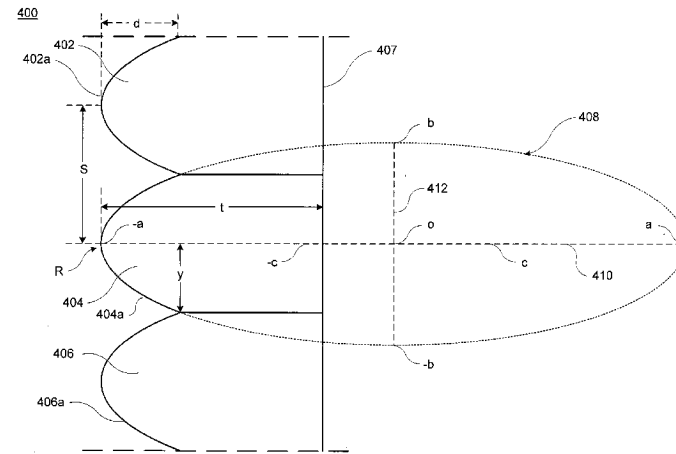

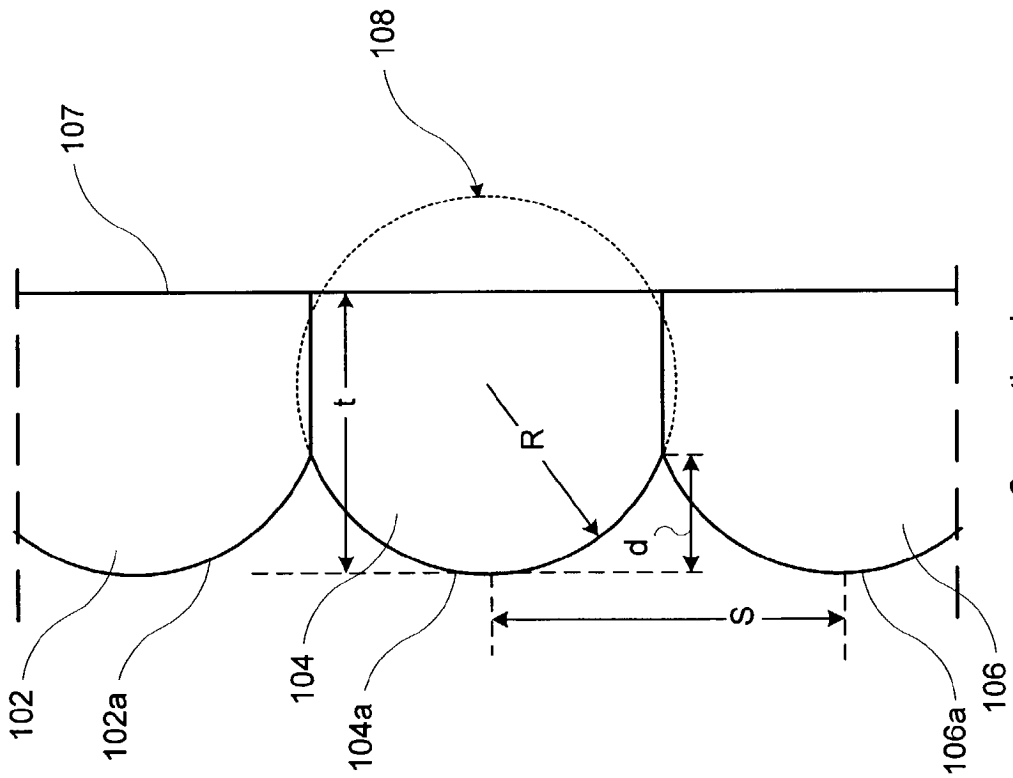

Conventional  
Figure 1

100

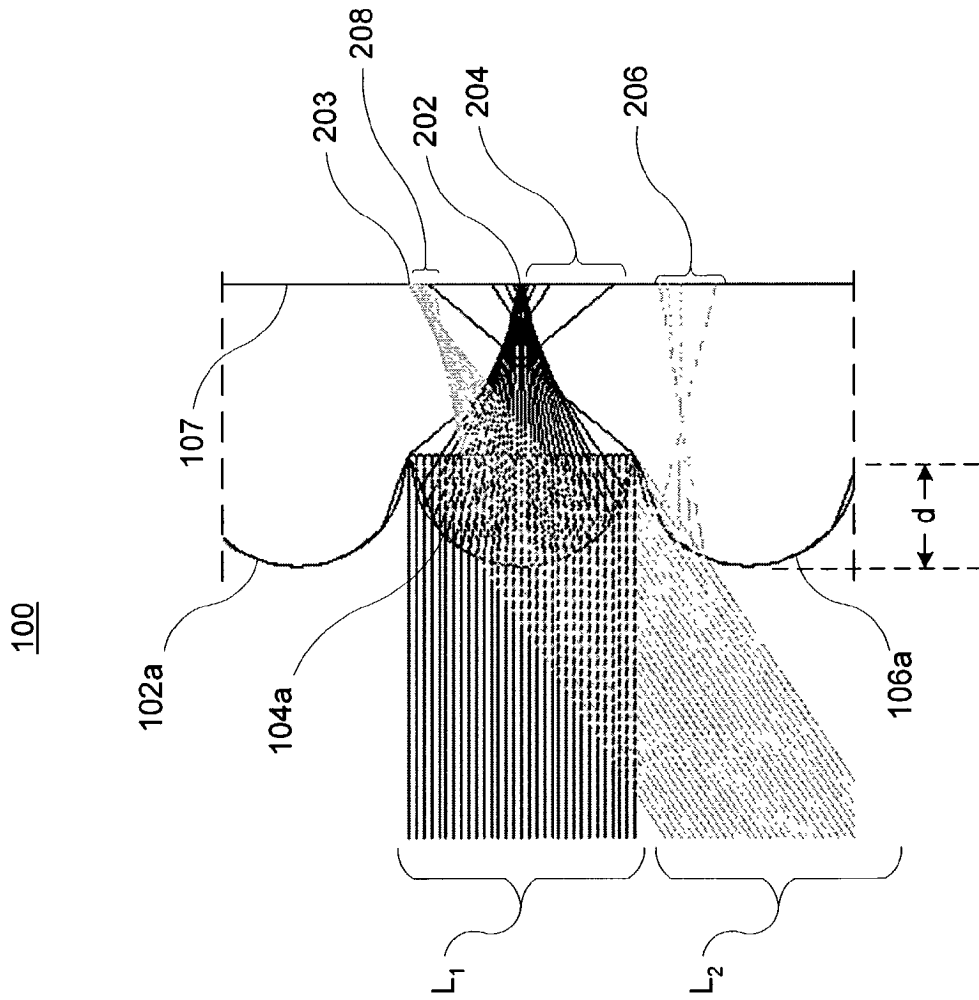

Conventional  
Figure 2

300

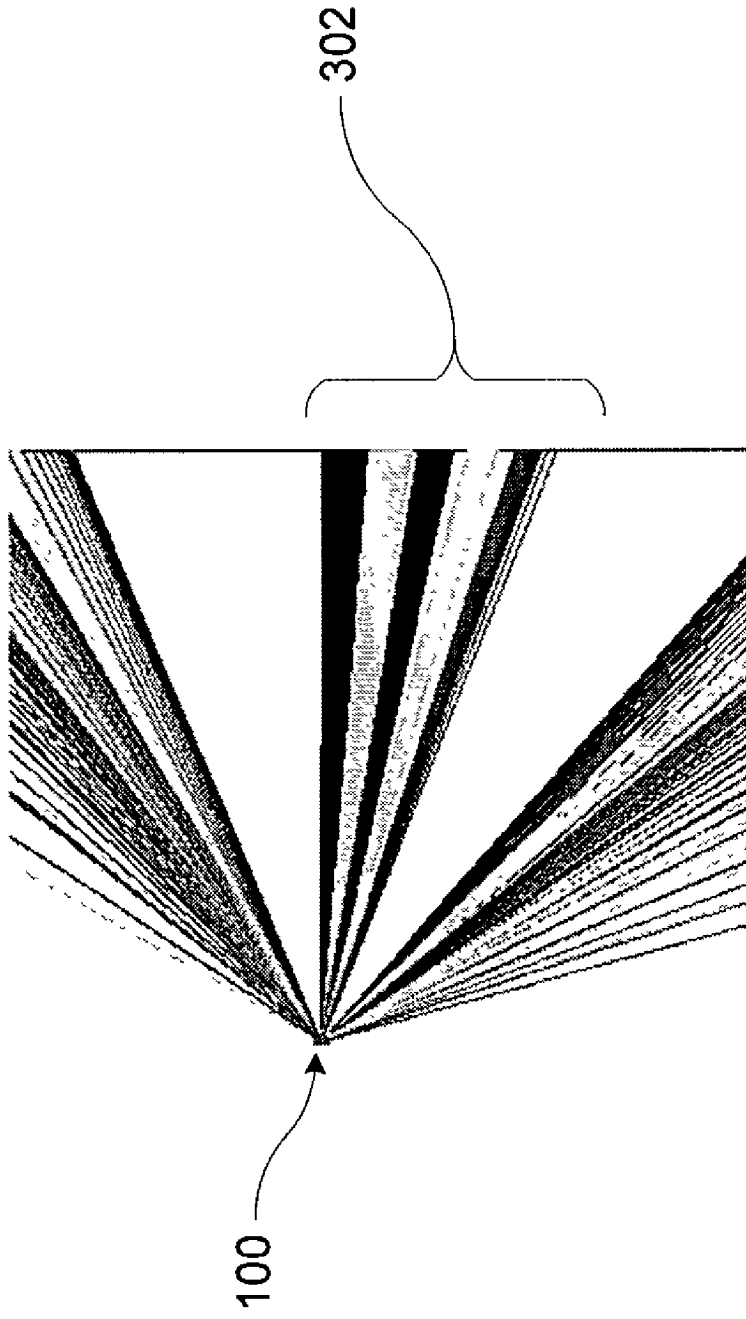

Conventional  
Figure 3

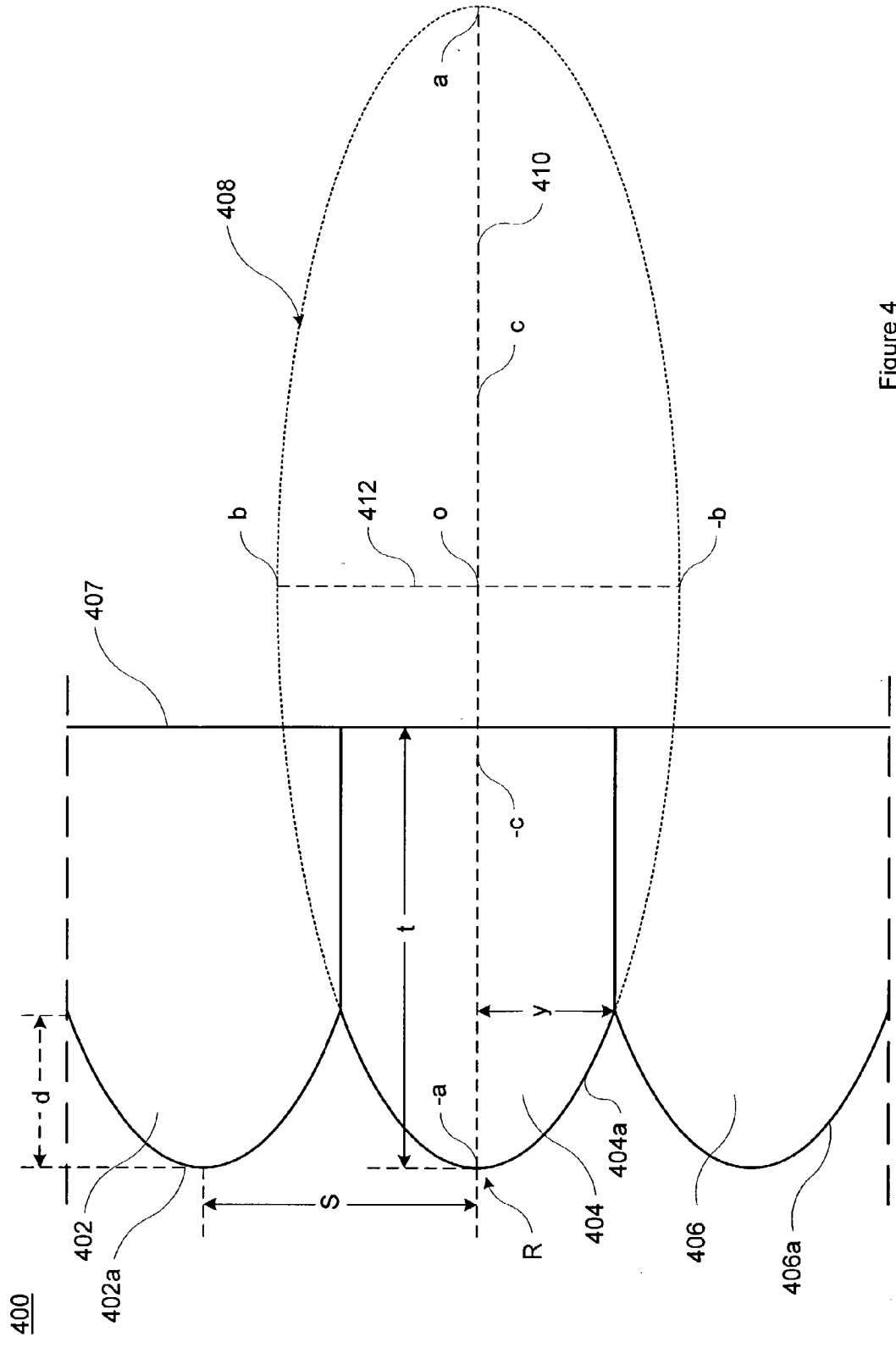

Figure 4

400

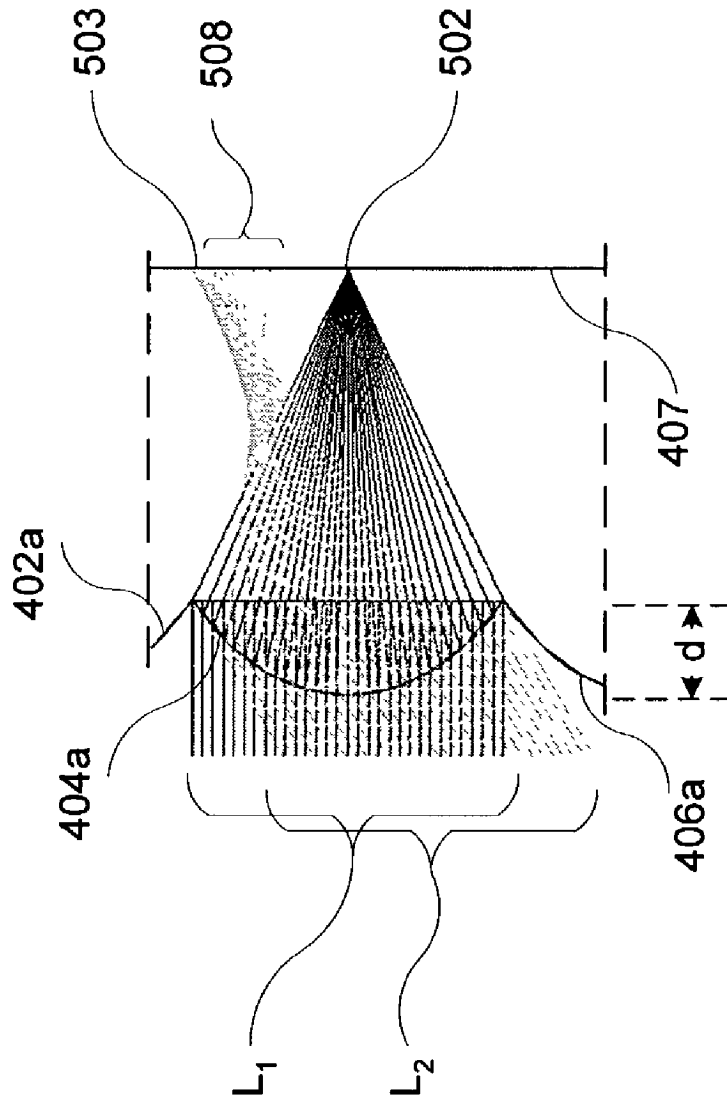

Figure 5

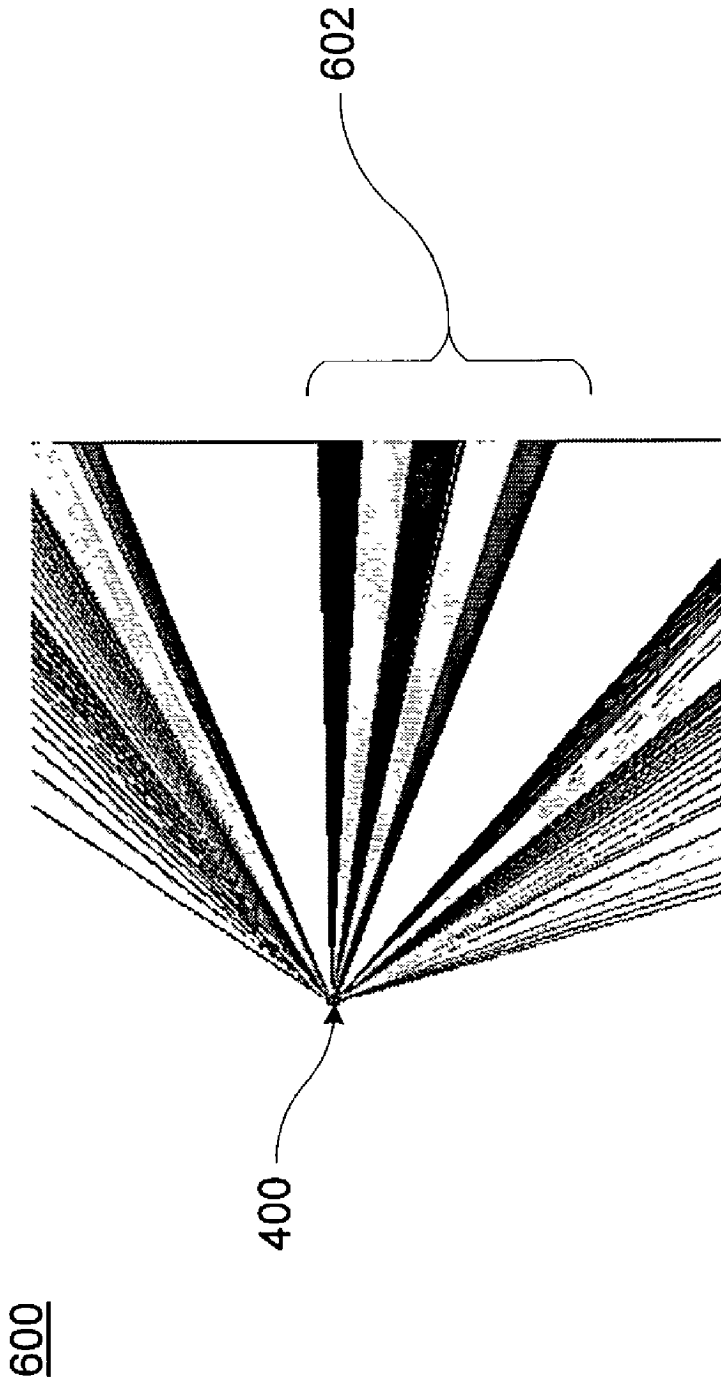

Figure 6

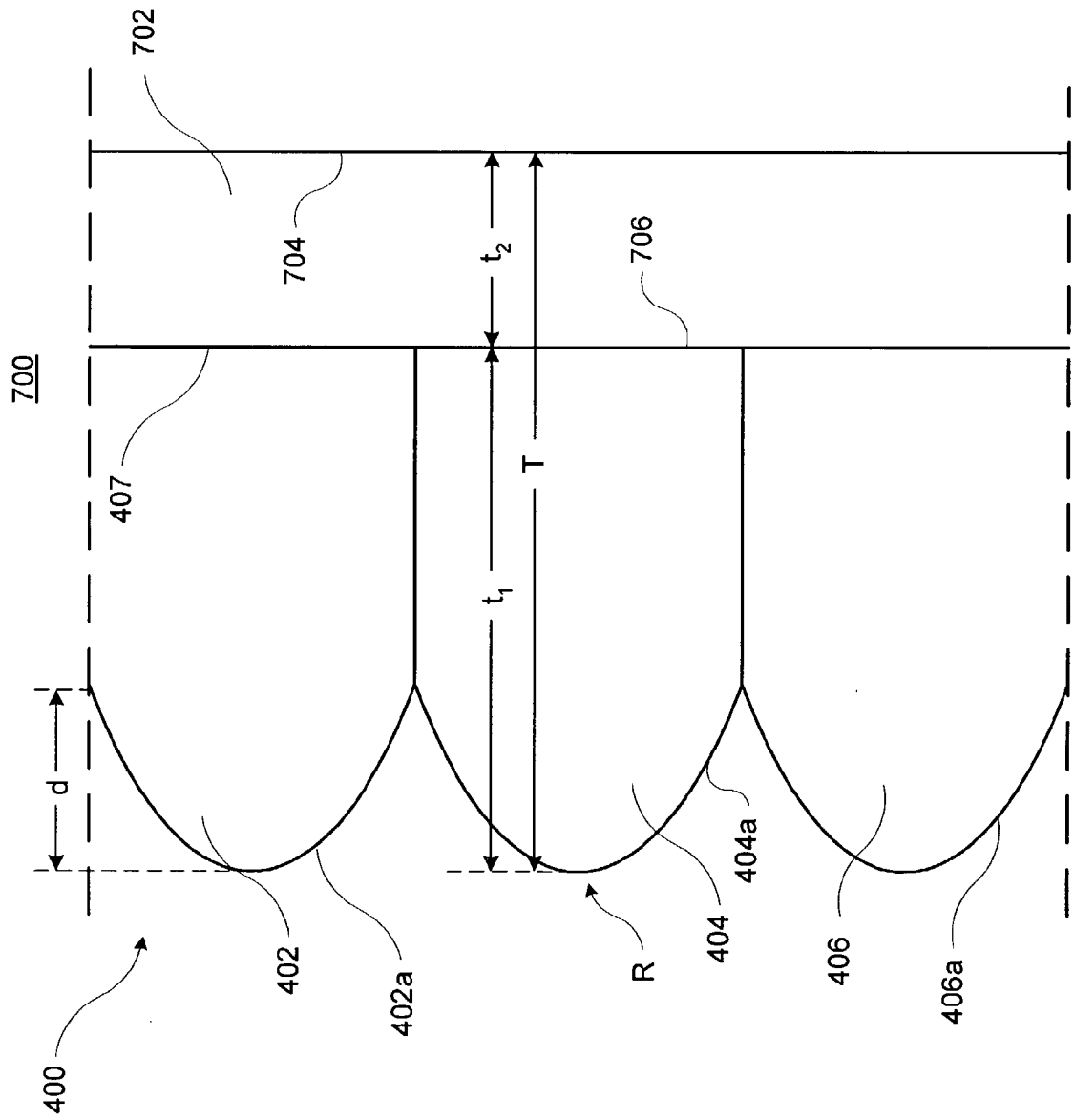

Figure 7

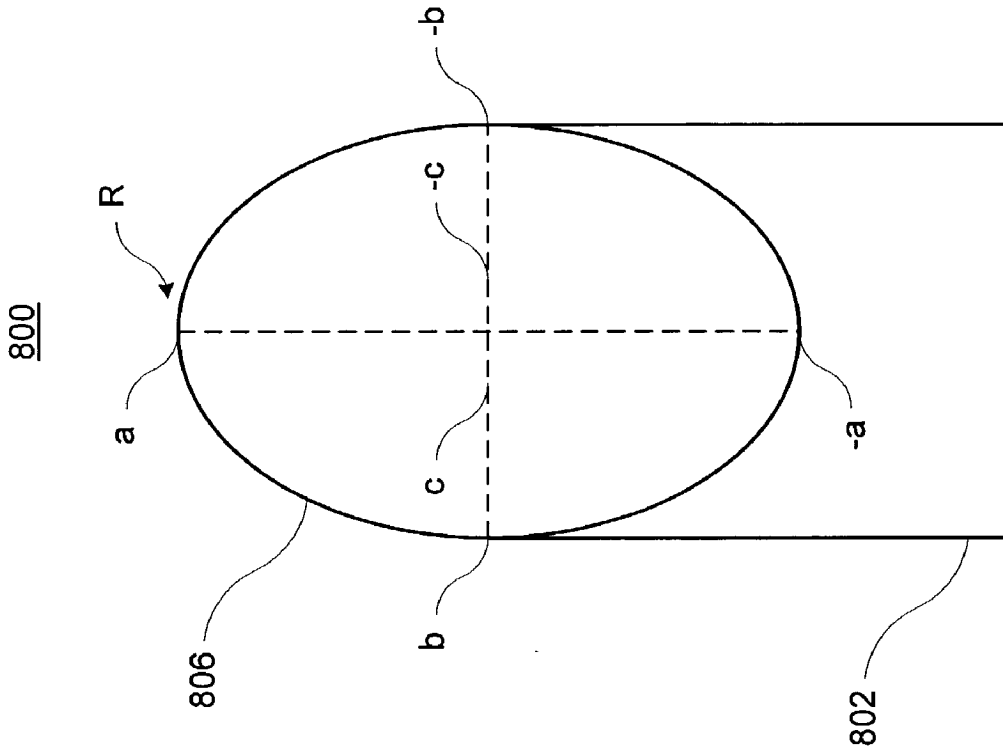

Figure 8B

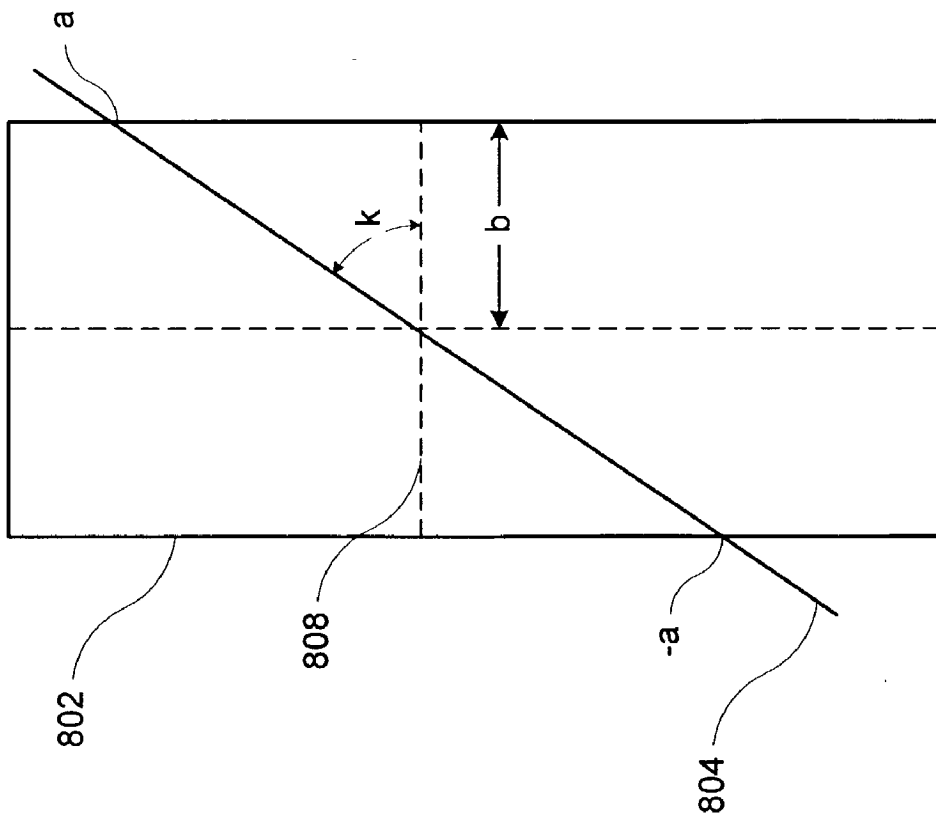

Figure 8A

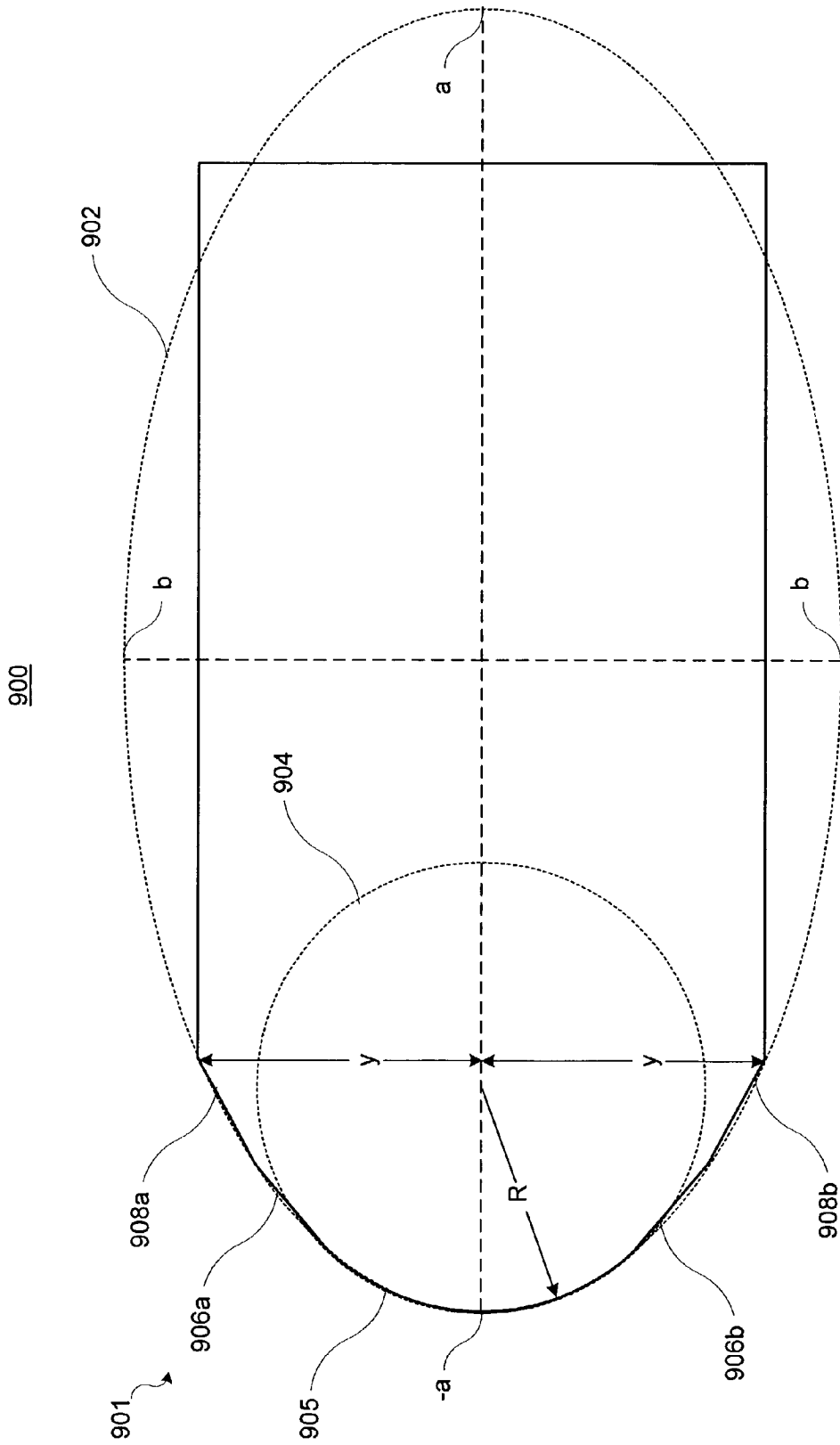

Figure 9

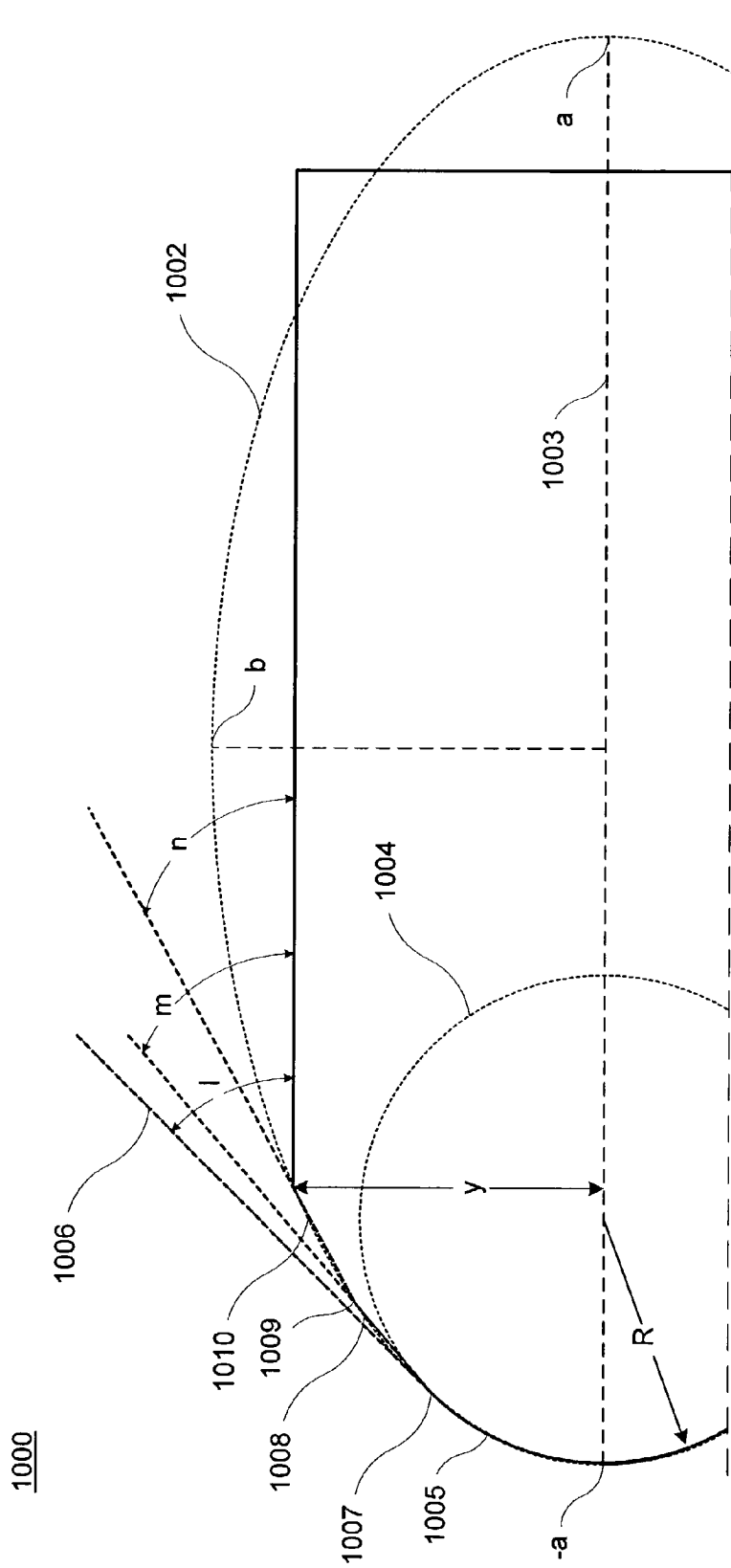

Figure 10

## LENTICULAR LENS ARRAY AND TOOL FOR MAKING A LENTICULAR LENS ARRAY

### PRIORITY AND RELATED APPLICATIONS

[0001] This application claims the benefit of priority to U.S. Provisional Patent Application Serial No. 60/297,148, entitled "Lenticular Lens Array Optimization for Printed Display," filed Jun. 8, 2001. The complete disclosure of the above-identified priority application is fully incorporated herein by reference.

### FIELD OF THE INVENTION

[0002] The present invention relates generally to a lenticular lens array for producing visual effects from interdigitated or interlaced images. More particularly, the present invention relates to a lenticular lens array where a cross section of each lens element on the array comprises an elliptical shape. The present invention also relates to a tool and a method for creating such a lenticular lens array.

### BACKGROUND OF THE INVENTION

[0003] A lenticular lens can create visual animated effects for interdigitated or interlaced (hereinafter "interlaced") printed images. The images can be printed using non-impact printing, known as masterless printing, or by conventional printing processes, known as master printing. Typically, a lenticular lens application comprises two major components: an extruded, cast, or embossed plastic lenticular lens and the interlaced printed image. The front of the lenticular lens comprises a plurality of lenticules arranged in a regular array, having cylindrical lens elements running parallel to one another. The back of the lenticular lens is flat and smooth. The interlaced images are printed on the flat, smooth backside of the lenticular lens. Exemplary methods for printing the images include conventional printing methods such as screen, letterpress, flexographic, offset lithography, and gravure; and non-impact printing methods such as electro-photography, iconography, magnetography, ink jet, thermography, and photographic. Any of the above printing technologies can be used in either sheet-fed or roll web-fed forms.

[0004] The interlaced images are viewed individually, depending on the angle through which a viewer observes the images through the lenticular lens elements. At a first viewing angle, a first image appears through the lenticular lens elements. As the lenticular lens is rotated, the first image disappears and another image appears through the lenticular lens elements. Viewing the images through the lenticular lens elements can create the illusion of motion, depth, and other visual effects. A lenticular lens can create those illusions through different visual effects. For example, the visual effects can comprise three-dimensions (3-D), animation or motion, flip, morph, zoom, or combinations thereof.

[0005] For a 3-D effect, multiple layers of different visual elements are interlaced together to create the illusion of 3-D, distance, and depth. For example, background objects are pictured with foreground objects that appear to protrude when viewed through a straight forward, non-angled view. For an animation or motion effect, a series of sequential photos can create the illusion of animated images. A viewer observes the series of photos as the viewing angle of the lens

changes. Animation is effective in showing mechanical movement, body movement, or products in use.

[0006] For a flip visual effect, two or more images flip back and forth as the viewing angle changes. The flip effect can show before-and-after and cause-and-effect scenarios. It also can show bilingual messages, such as flipping from English to Spanish. For a morph visual effect, two or more unrelated images gradually transform or morph into one another as the viewing angle of the lenticular lens changes. Finally, for a zoom effect, an object moves from the background into the foreground as the viewing angle of the lenticular lens changes. The object also may travel from side to side, but usually works better in a top to bottom format.

[0007] FIG. 1 illustrates a partial cross section of a conventional lenticular lens array 100. The array 100 comprises lenticules 102, 104, 106. Each lenticule 102, 104, 106 comprises a cylindrical lens element 102a, 104a, 106a, respectively. Each lens element 102a, 104a, 106a operates to focus light on a back surface 107 of the array 100. In operation of the conventional array 100, multiple images can be printed on the rear surface 107. An observer can singularly view the images through the lens elements 102a, 104a, 106a by rotating the array 100.

[0008] Specific characteristics of each lenticule 102, 104, 106 will be described with reference to exemplary lenticule 104. Each lens element 102a, 104a, 106a has a circular cross section of radius R. The circular cross section corresponds to a desired circular shape 108 having the radius R. The lens element 104a comprises a portion of the circular shape 108. Lenticule 104 also has a distance t from a vertex of the lens element 104a to the rear surface 107 of the array 100. The lens element 104a has a lens junction depth d where it joins adjacent lens elements 102a, 106a. Finally, the material forming the lens array 100 determines a refractive index N of the array 100.

[0009] The relationship between the distance t, the radius R, and the refractive index N is given by the following equation:

$$t = \frac{RN}{N-1} \quad (1)$$

[0010] As shown in equation (1), the thickness t and radius R are a function of the refractive index N, which is a function of wavelength of light. Accordingly, the lenticular lens elements can be optimized for a particular wavelength based on the wavelength that provides the best overall performance for the desired application.

[0011] Regularity of the array 100 can be defined by the separation or distance S between the vertex of adjacent lens elements. For the conventional cylindrical lenticular lens array 100, the maximum separation between the vertex of each lens element 102a, 104a, 106a is given by the following equation:

$$S_{\max} = 2R \quad (2)$$

[0012] A pitch P of the lenticules can be defined as a number of lenticules per unit length (lpu). For example, the unit length can comprise an inch or a millimeter. For the

conventional cylindrical lenticular lens array **100**, the minimum pitch is given by the following equation:

$$P_{\min} = \frac{1}{2R} [lpu] \quad (3)$$

[0013] FIG. 2 illustrates a light ray trace illustrating several problems associated with a conventional lenticular lens array **100**. In general, the array **100** operates by passing light from the rear surface **107** through the lens elements **102a**, **104a**, **106a** to an observer. Reciprocity allows viewing the light path in reverse as illustrated in FIG. 2. Ideally, on-axis light  $L_1$  passes through lens element **104a** and is focused to a common point **202** on the rear surface **107** of the array **100**. However, the circular cross-section of the lens element **104a** produces a projected image having spherical aberration. For example, the light  $L_1$  is projected over a large area **204** on the rear surface **107**. The large projection area limits resolution and the number of interlaced images that can be viewed on the rear surface **107**.

[0014] Additionally, off-axis light  $L_2$  passes through the lens element **104a** and is focused upon the rear surface **107** near point **203**. However, the circular cross-section of lens element **104a** produces coma and an astigmatic aberration **208**. Finally, FIG. 2 illustrates that the depth  $d$  of the lens surface can approach the radius of the circular cross-section at the junction of adjacent lenses. Accordingly, portions of the light  $L_2$  are blocked by lens **106a** and may be redirected to the wrong location **206**.

[0015] FIG. 3 illustrates a light beam projection illustrating another problem associated with the conventional lenticular lens array **100**. FIG. 3 illustrates light beams projected to an observer from different printed areas of the conventional lenticular lens array **100**. As shown, the light beams in the central area **302** are not reasonably matched over the circular angle of the lens.

[0016] Furthermore, conventional lenticular sheet-fed printing has been used to create promotional printed advertising pieces printed on a lenticular lens array. For example, the advertising pieces include limited volumes of thicker gauge lenticular material designs such as buttons, signage, hang tags for clothing, point-of-purchase displays, post-cards, greeting cards, telephone cards, trading cards, credit cards, and the like. Those thicker gauge lenticular printed products are printed on cylindrical lenticular material having a standard thickness. For example, standard thicknesses include 0.012 mil, 0.014 mil, 0.016 mil, 0.018 mil, and up to 0.0900 mil. Printed quality on those thicker lenses are generally acceptable because the lenticule pitch is more coarse (fewer lenticules) and the printing process can place more printed image pixels within the lenticule band range. Additionally, lenticular materials at the thicker ranges tend to be more optically forgiving than thinner gauges.

[0017] Recently, lenticular extruders, lenticular casting/embossers, and print manufacturers have experimented with decreasing the overall lenticular material thickness using the common cylindrical lens elements discussed above. However, as the thickness of the lenticular lens array decreases, the print quality suffers significant aberration. As the thickness decreases, lenticule pitch must increase to provide more

lenticules per unit length, thereby reducing the separation between lenticules. That thinner configuration does not allow using as many printed pixel images when compared to the thicker lenticular material designs. Accordingly, the quality of the printed visual effects is degraded with the thinner material.

[0018] Another problem with thicker lenticular materials is that the thicker materials cannot be used for the majority of the consumer packaging industry. That problem arises because thicker materials of 0.012 mil and thicker cannot be applied nor handled properly to cylindrical or truncated package shapes without de-laminating off the package due to plastic memory pull. Even when a strong adhesive is used to bond the thick lenticular piece to the packaged unit, problems with de-lamination still occur over time due to the continual pull of the plastic material, as the plastic memory pulls the material to its natural, straight produced shape.

[0019] Thicker lenticular materials also experience problems during the label application process. Automated printed label blow-down or wipe-down packaging labeling equipment cannot apply the thicker lenticular materials, because of the plastic memory issues discussed above. The plastic memory causes the thicker lenticular die cut labels to rise off the lenticular label rolls before the application process.

[0020] Therefore, a need in the art exists for a lenticular lens array that can provide a more focused or resolved image by mitigating the spherical aberration associated with conventional arrays. A need in the art also exists for a tool and a method for making such a lenticular lens array. Furthermore, a need exists in the art for a lenticular lens array having a lenticular lens element shaped to mitigate the spherical aberration associated with conventional lenticular lens elements. A need also exists for a lenticular lens array having a thin structure to mitigate plastic memory issues associated with thicker, conventional arrays.

## SUMMARY OF THE INVENTION

[0021] The present invention can provide a lenticular lens array that can optimize printed display quality of animated/three-dimensional images for mass production. The present invention can provide a lenticular lens array that can mitigate the spherical aberration typically produced by a conventional array. For example, the present invention can provide a lenticular lens array that can produce a substantially focused axial image and can improve the off-axis image. Additionally, the present invention can provide a lenticular lens array having a reduced lens junction depth, which can mitigate off-axis light blocking by adjacent lenses.

[0022] The lenticular lens array according to the present invention can comprise a plurality of lenticules disposed adjacent to each other. Each lenticule can comprise a lenticular lens element on one side and a substantially flat surface on an opposite side. Each lenticular lens element can have a vertex and a cross section comprising a portion of an elliptical shape. Alternatively, the cross section can comprise an approximated portion of an elliptical shape. The elliptical shape can comprise a major axis disposed substantially perpendicular to the substantially flat surface of each respective lenticular lens element. The vertex of each respective lenticular lens element can lie substantially along the major axis of the elliptical shape.

[0023] These and other aspects, objects, and features of the present invention will become apparent from the following detailed description of the exemplary embodiments, read in conjunction with, and reference to, the accompanying drawings.

#### BRIEF DESCRIPTION OF THE DRAWINGS

[0024] FIG. 1 illustrates a partial cross section of a conventional lenticular lens array.

[0025] FIG. 2 illustrates a light ray trace illustrating problems associated with a conventional lenticular lens array.

[0026] FIG. 3 illustrates a light beam projection illustrating another problem associated with the conventional lenticular lens array.

[0027] FIG. 4 illustrates a partial cross section of a lenticular lens array according to an exemplary embodiment of the present invention.

[0028] FIG. 5 illustrates a light ray trace illustrating optical characteristics of a lenticular lens array according to an exemplary embodiment of the present invention.

[0029] FIG. 6 illustrates a light beam projection illustrating additional optical characteristics of the lenticular lens array according to an exemplary embodiment of the present invention.

[0030] FIG. 7 illustrates a partial cross section of a lenticular lens array according to an alternative exemplary embodiment of the present invention.

[0031] FIG. 8A illustrates a cross-section of a cylindrical rod for producing a tool for forming elliptically-shaped lens elements according to an exemplary embodiment of the present invention.

[0032] FIG. 8B illustrates a front view of the tool for forming elliptically-shaped lens elements according to an exemplary embodiment of the present invention.

[0033] FIG. 9 illustrates a cross section of a pseudo elliptical lenticule for approximating an elliptically shaped lens element of a lenticular lens array according to an exemplary embodiment of the present invention.

[0034] FIG. 10 illustrates a pseudo elliptical tool for creating a pseudo elliptical lens element according to an exemplary embodiment of the present invention.

#### DETAILED DESCRIPTION OF EXEMPLARY EMBODIMENTS

[0035] The present invention can reduce spherical aberration associated with conventional lenticular lens arrays by providing a lenticular lens array having an elliptical cross-sectional shape. The elliptical cross-sectional shape can provide sharp focusing of on-axis light and can increase the clarity of off-axis light. The characteristic shape of the elliptical cross section can be determined based on a particular application. Many parameters can influence the elliptical shape. For example, the parameters include a refractive index  $N$  of the array material, a thickness  $t$  from the vertex

of each lens element to a rear surface of the array, a lens junction depth  $d$  where adjacent lenses join, and other parameters. A pseudo elliptical lens element also can provide a lenticular lens array having reduced spherical aberration.

[0036] FIG. 4 illustrates a partial cross section of a lenticular lens array 400 according to an exemplary embodiment of the present invention. The array 400 comprises lenticules 402, 404, 406. Each lenticule 402, 404, 406 comprises an elliptically-shaped lens element 402a, 404a, 406a, respectively. Each lens element 402a, 404a, 406a operates to focus light on a back surface 407 of the array 400. In operation of the array 400, multiple images can be printed on the rear surface 407 of the array 400. An observer can singularly view the images through the lens elements 402a, 404a, 406a by rotating the array 400.

[0037] Specific characteristics of each lenticule 402, 404, 406 will be described with reference to exemplary lenticule 404. Each lens element 402a, 404a, 406a has an elliptical cross section corresponding to a portion of a desired elliptical shape 408. The lens element 404a comprises a portion of the elliptical shape 408. At a vertex of the lens element 404a, the elliptical shape 408 has a radius  $R$ . Lenticule 404 also has a distance  $t$  from a vertex of the lens element 404a to the rear surface 407 of the array 400. The lens element 404a has a lens junction depth  $d$  where it joins adjacent lens elements 402a, 406a. The material forming the lens array 400 determines a refractive index  $N$  of the array 400. The relationship between the distance  $t$ , the radius  $R$ , and the refractive index  $N$  is given by equation (1) discussed above.

[0038] The characteristics of the elliptical shape 408 will now be described. The elliptical shape 408 comprises an ellipse having a major axis 410 and a minor axis 412. The ellipse crosses the major axis 410 at points  $\pm a$  and the minor axis 412 at points  $\pm b$ . The major axis 410 and the minor axis 412 cross at the origin  $o$ . The ellipse also comprises foci located at points  $\pm c$  on the major axis 410. The junction point of adjacent lens elements 402a, 404a, 406a crosses the elliptical shape 408 at a distance  $y$  from the major axis 410. The optical axis of the lenticule 404, which is the major axis 410 of the elliptical shape 408, is perpendicular to the rear surface 407 of the array 400. The vertex of the lens element 404a is positioned along the major axis 410 of the elliptical shape 408.

[0039] For the lenticular lens array 400, the maximum separation between the vertex of each lens element 402a, 404a, 406a is given by the following equation:

$$S_{\max} = 2b \quad (4)$$

[0040] The maximum separation between the vertex of each lens element 402a, 404a, 406a also is given by the following equation:

$$S_{\max} = \frac{2RN}{\sqrt{N^2 - 1}} \quad (5)$$

[0041] The array 400 has a pitch defined by the number of lenticules per unit length (lpu). For example, the unit length can comprise an inch or a millimeter. For the lenticular lens

array **400**, the minimum pitch is given by the following equation:

$$P_{\min} = \frac{1}{2b} [lpu] \quad (6)$$

[0042] Parameters for a particular application of the lenticular lens array **400** can determine the characteristics of the elliptical shape **408**. The characteristics can be determined for each application. For example, the characteristics  $d$ ,  $t$ ,  $y$ , and  $R$  of the elliptical shape **408** can be determined from the refractive index of the material forming the array **400** and standard geometric equations. For instance, the major axis **410** can lie along an  $x$ -axis and the minor axis **412** can lie along a  $y$ -axis of a rectangular coordinate system. Accordingly, the elliptical shape **408** is given by the following equation:

$$y^2 - 2Rx + px^2 = 0 \quad (7)$$

[0043] The constant  $p$  can be determined in terms of a conic constant as shown in the following equation:

$$p = \kappa + 1 \quad (8)$$

[0044] The conic constant  $\kappa$  can define the elliptical shape of the lens **404** and can be determined from the following equation:

$$\kappa = -\frac{1}{N^2} \quad (9)$$

[0045] The refractive index  $N$  is typically in the range of about 1.3 to about 2.0, and more commonly in the range of about 1.5 to about 1.6, for plastics used in the printing industry. Accordingly, the conic constant  $\kappa$  for the bounding refractive index range covers from about  $-0.25$  to about  $-0.60$ . Accordingly, those conic constants indicate an elliptical shape for the lens element **404a**, because a conic constant less than zero and greater than minus one indicates an elliptical shape.

[0046] The eccentricity  $e$  of the elliptical shape **408** is given by the following equations:

$$e = \sqrt{-\kappa}, \text{ or} \quad (10)$$

$$e = \frac{c}{a} \quad (11)$$

[0047] Other standard geometric relationships for the elliptical shape **408** include the following:

$$a = \frac{R}{p}, \text{ or} \quad (12)$$

$$a = \frac{R}{\kappa + 1} \quad (13)$$

$$b^2 = a^2 - c^2 \quad (14)$$

[0048] An example of determining particular characteristics for the elliptical shape **408** will now be described. A

desired material to form the array **400** can be chosen. The desired material can have an associated refractive index  $N$ . Using the refractive index  $N$ , a conic constant  $\kappa$  for the elliptical shape **408** can be determined using equation (9). Additionally, a lenticule thickness  $t$  can be chosen for the particular application. For example, the lens thickness  $t$  can be in the range of about 0.003 to about 0.100 inches. In an exemplary embodiment, the lenticule thickness  $t$  can be chosen in the range of about 0.007 to about 0.011 inches. Alternatively, the lenticule thickness  $t$  can be determined using the standard geometric equations, the points  $\pm a$  and  $\pm b$  that define the elliptical shape **408** can be determined. For example, the radius  $R$  can be determined using equation (1) and the conic constant  $\kappa$  from equation (9). Then, points  $\pm a$  can be determined using equation (12) or (13). Next, the eccentricity  $e$  can be determined using equation (10). Points  $\pm c$  can be determined using equation (11). Points  $\pm b$  can be determined using equation (14).

[0049] The distance  $y$  can be chosen based on the particular application for the array **400**. The distance  $y$  is one half the width of the lens element **404a**. The width of the lens element **404a** can define a field of view for the lens element **404a** on the rear surface **407**. Accordingly, the distance  $y$  can be chosen to provide a field of view wide enough for a desired number of interlaced images. After choosing the distance  $y$ , the  $x$  coordinate on the major axis **410** for the distance  $y$  can be determined using equation (7).

[0050] The particular characteristics of the elliptical shape **408** can be determined from many combinations of the parameters that define those characteristics. Accordingly, the present invention encompasses determining elliptical characteristics based on a different set of chosen or given initial parameters than those described above.

[0051] FIG. 5 illustrates a light ray trace illustrating optical characteristics of the lenticular lens array **400** according to an exemplary embodiment of the present invention. The lenticular lens array **400** can mitigate the spherical aberration typically produced by a conventional array. For example, the array **400** can provide a substantially focused axial image and can improve the off-axis image. As shown in FIG. 5, the on-axis light  $L_1$  can pass through the lens element **404a** of the array **400** and can be focused at point **502** on the rear surface **407**. As shown, the elliptically-shaped lens element **404a** can mitigate spherical aberration produced around the focal point **502**. By reducing the base spherical aberration, spherochromatism can also be reduced.

[0052] Additionally, the off-axis image produced from the off-axis light  $L_2$  at point **503** is improved over the conventional lens, with coma **508** being the clear residual aberration. Also, the elliptically-shaped lens element **404a** can reduce the lens junction depth  $d$  between adjacent lens elements. Accordingly, the array **400** can mitigate off-axis light blocking by adjacent lenses, as shown in FIG. 4. For a given width  $2y$ , radius  $R$ , and index of refraction  $N$ , ghosting can be reduced because off-axis light blocking is reduced compared to a conventional circular array having the same width, radius, and index of refraction characteristics.

[0053] FIG. 6 illustrates a light beam projection illustrating additional optical characteristics of the lenticular lens array **400** according to an exemplary embodiment of the present invention. FIG. 6 illustrates light beams projected to

an observer from different printed areas of the lenticular lens array **400**. As shown, the light beams in the central area **602** are reasonably matched over the angle of the elliptically-shaped lens.

[0054] FIG. 7 illustrates a partial cross section of a lenticular lens array **700** according to an alternative exemplary embodiment of the present invention. The array **700** can comprise the lenticular lens array **400** coupled to a substrate **702**. In the exemplary embodiment, the lens elements **402a**, **404a**, and **406a** can focus light on a rear surface **704** of the substrate **702**. The total distance T from each lens vertex to the rear surface **704** of the substrate **702** can comprise the distance  $t_1$  from the lens vertex to the rear surface **407** of the array **400** plus the distance  $t_2$  from the rear surface **407** of the array **400** to the rear surface **704** of the substrate **702**. In practice, the lenticular lens array is cast and has a thickness  $t_1$  typically equal to about lens junction depth d or slightly greater than the lens junction depth d. The characteristics of the elliptically-shaped lenses **402a**, **404a**, **406a** can be similar to those described above with reference to FIG. 4.

[0055] The array **400** and the substrate **702** can comprise different materials. Accordingly, the different materials can have different refractive indexes. For example, the array **400** can comprise a material having a refractive index of  $N_1$ , and the substrate **702** can comprise a material having a refractive index of  $N_2$ . The different refractive indices of the array and substrate materials can introduce additional spherical aberration. For example, for a single additional substrate of thickness  $t_2$  and refractive index  $N_2$ , the focal displacement is shifted with respect to an array comprising a single material of refractive index  $N_1$  and having the same R. The shift in focal displacement can be either positive or negative depending upon the relationship of the materials. To compensate for the different refractive indices, equation (1) can be modified to the following equation to determine the radius R of each lens element **402a**, **404a**, **406a** when the array **700** comprises two or more different materials:

$$R = (N_1 - 1) \left( \frac{t_1}{N_1} + \frac{t_2}{N_2} + \dots + \frac{t_n}{N_n} \right) \quad (15)$$

[0056] The value of the radius R results in the image from a distant source being formed upon the back surface of the substrate **702**. As shown above, equation (15) can apply when the lenticular lens array comprises more than one substrate.

[0057] The conic constant can be estimated from equation (9) and can be optimized with an optical computer program to mitigate the additionally induced spherical aberration of the substrate(s).

[0058] In an alternative exemplary embodiment, the substrate **702** can be bonded to the array **400** through a bonding layer (not shown) such as a resin. Typically, a bonding layer will have a finite thickness and an associated index of refraction. If a bonding layer is used, it can be treated as an additional substrate. Accordingly, equation (15) can be used to compensate for the thickness and index of refraction of the bonding layer, as well as for that of the substrate. The associated conic constant is determined and optimized in the manner previously described.

[0059] In another alternative exemplary embodiment, the substrate **702** can comprise an adhesive layer.

[0060] In another alternative exemplary embodiment, the substrate **702** can comprise an opaque substrate. For example, the opaque substrate can comprise paper. Additionally, the interlaced image can be printed on a front surface **706** of the opaque substrate. Then, the opaque substrate can be laminated to the lenticular lens array **400**. In that case, the image is located at the rear surface **407** of the array **400**. Accordingly, the thickness of the substrate does not have to be considered to determine the proper thickness T. However, if a bonding layer is used to laminate the opaque substrate to the array **400**, then the thickness of the bonding layer should be considered to determine the proper thickness T.

[0061] In another alternative exemplary embodiment, the lenticules **402-406** can be cast onto the substrate **702** such that a discontinuity exists between one or more pairs of adjacent lenticules. For example, the lenticules **402-406** can be cast onto the substrate **702** such that a discontinuity exists between lenticules **402** and **404** or between lenticules **404** and **406**.

[0062] A tool **800** for producing an elliptically-shaped lens element according to an exemplary embodiment of the present invention will now be described with reference to FIGS. **8A** and **B**. Tool **800** can be constructed from diamond or other suitable material. FIG. **8A** illustrates a cross-section of a base member **802** for producing the tool **800** for forming elliptically-shaped lens elements according to an exemplary embodiment of the present invention. FIG. **8B** illustrates a front view of the tool **800** for forming elliptically-shaped lens elements according to an exemplary embodiment of the present invention.

[0063] The tool **800** can be used to produce a regular array of groves in a mandrel for casting or extruding the lenticular lens array. The tool **800** is not used to directly form the lenticular lens array. For example, the mandrel can comprise a drum, and the tool **800** can produce a spiral or screw pattern in the drum. Alternatively, the tool **800** can produce a straight-cut (parallel-grooved) pattern in the drum. Furthermore, the mandrel can be coated with a copper alloy prior to being shaped by the tool **800**. The copper alloy can be used because it cuts cleanly and holds its shape. After cutting, the copper alloy can be plated with another material to improve the mandrel's durability. For example, the plating material can comprise chrome. If a coating or plating material is used after cutting, then the dimensions of the tool **800** can be adjusted (increased) to compensate for a finite thickness of the coating or plating material. The following description details a tool that creates a mandrel without a coating or plating. In practice, the size of the tool **800** can account for the added thickness of the coating or plating.

[0064] As shown in the exemplary embodiments of FIGS. **8A** and **8B**, the base member **802** can comprise a cylindrical rod and can have a radius b corresponding to the dimensions  $\pm b$  of an elliptical shape **806** for the tool **800**. The base member **802** can be cut along a plane **804** at an angle  $\kappa$  to

a minor axis **808** of the base member **802**. The angle  $\kappa$  can be determined from the following equation:

$$\cosine(k) = \frac{b}{a} \quad (16)$$

[**0065**] The elements  $b$  and  $a$  correspond to elliptical characteristics of the elliptical shape **806**. The elliptical shape **806** corresponds to the desired elliptical shape of lenticular lens elements on a lenticular lens array according to an exemplary embodiment of the present invention. Accordingly, each of the elliptical characteristics  $a$ ,  $b$ , and  $c$ , correspond to the same characteristics for the elliptically shaped lens elements of the array.

[**0066**] In an alternative exemplary embodiment, the base member **802** can comprise a cone. The cone can comprise a truncated cone. The cone can comprise diamond or other suitable material. Standard geometric equations can be used to determine a proper angle to cut the cone to produce the desired elliptical shape for the tool **800**. Accordingly, the cone can be cut at an angle to produce the desired elliptical shape for the tool. Potential advantages of a truncated conical base member **802** include less material being required and the conical apex angle providing a general reduction in angular range capability of the fabrication equipment.

[**0067**] The tool **800** comprises a mother tool that can be used to cut a mandrel for producing elliptically-shaped lens elements of the array. The mandrel then can be used to create the elliptically-shaped lens elements in a lenticular lens array. For example, the mandrel can be used for casting or extruding the lenticular lens elements of the array.

[**0068**] **FIG. 9** illustrates a pseudo elliptical lenticule **900** for approximating an elliptically shaped lens element of a lenticular lens array according to an exemplary embodiment of the present invention. The lenticule **900** can be included in a lenticular lens array according to an exemplary embodiment of the present invention. The lenticule **900** comprises a pseudo elliptical lens element **901**. As shown, the pseudo elliptical lens element **901** approximates a portion of an elliptical shape **902**. The pseudo elliptical lens element **901** comprises a circular portion **905**, corresponding straight portions **906a**, **906b**, and corresponding straight portions **908a**, **908b**.

[**0069**] The circular portion **905** comprises a portion of a circular shape **904** that approximates the radius  $R$  of the elliptical shape **902**. Accordingly, the circular shape **904** can have a radius equal to the radius  $R$  of the elliptical shape. Alternatively, the circular shape **904** can have a radius different from the radius  $R$  of the elliptical shape, if the different radius can better approximate the elliptical shape. The circular portion **905** can comprise that portion of the circular shape **904** that approximates the elliptical shape **902** within a specified tolerance. The specified tolerance can be determined based on a desired projected image quality for a particular application. The maximum residual shape error of the circular and straight regions can be maintained to be approximately the same.

[**0070**] Corresponding straight portions **906a**, **906b** can be provided beginning at a point where the circular shape **904**

exceeds the specified tolerance from the elliptical shape **902**. Accordingly, straight portions **906a**, **906b** can approximate a portion of the desired elliptical shape **902**.

[**0071**] Corresponding straight portions **908a**, **908b** can be provided beginning at a point where the straight portions **906a**, **906b**, respectively, exceed the specified tolerance from the elliptical shape **902**. The straight portions **908a**, **908b** can approximate a portion of the desired elliptical shape **902**.

[**0072**] Any number of straight portions can be used to approximate the elliptical shape **902**. The number of straight portions can be adjusted to minimize deviation from the elliptical shape **902**. For example, using more straight portions can achieve less deviation from the desired elliptical shape **902**. In other words, a smaller tolerance limit can be used when more straight portions are used. Typically, if more straight portions are used, then a smaller circular portion **905** can be used to allow a smaller tolerance limit.

[**0073**] In an alternative exemplary embodiment, a plurality of facets can be used to approximate the desired elliptical shape without using a circular portion. In one embodiment, corresponding pairs of facets can be used to approximate the desired elliptical shape. In that embodiment, the pseudo elliptical lens elements can have a point where a facet pair meets at the vertex of the lens element. In an alternative embodiment, the vertex can be approximated with a single facet positioned substantially orthogonal to the major axis of the elliptical shape, and corresponding pairs of facets can be used to approximate outer portions of the elliptical shape.

[**0074**] Accordingly, the pseudo elliptical lens element **901** can approximate an elliptical shape **902**, thereby improving the image characteristics in a similar manner as described above for the array **400** of **FIG. 4**.

[**0075**] **FIG. 10** illustrates a pseudo elliptical tool **1000** for creating a pseudo elliptical lens element according to an exemplary embodiment of the present invention. The tool **1000** can be used to produce a regular array of grooves in a mandrel for casting or extruding the lenticular lens array. The tool **1000** is not used to directly form the lenticular lens array. For example, the mandrel can comprise a drum, and the tool **1000** can produce a spiral or screw pattern in the drum. Alternatively, the tool **1000** can produce a straight-cut (parallel grooved) pattern in the drum. Furthermore, the mandrel can be coated with a copper alloy prior to being shaped by the tool **1000**. The copper alloy can be used because it cuts cleanly and holds its shape. After cutting, the copper alloy can be plated with another material to improve the mandrel's durability. For example, the plating material can comprise chrome. If a coating or plating material is used after cutting, then the dimensions of the tool **1000** can be adjusted (increased) to compensate for a finite thickness of the coating or plating material. The following description details a tool that creates a mandrel without a coating or plating. In practice, the size of the tool **1000** can account for the added thickness of the coating or plating.

[**0076**] In **FIG. 10**, only one side of the elliptical tool **1000** is illustrated. The other side of the elliptical tool **1000** comprises a mirror image of the illustrated side. The elliptical tool **1000** can be constructed from diamond or other suitable material. The elliptical tool **1000** can comprise a tool for cutting a form that can be used to extrude or cast

pseudo elliptical lens elements of a lenticular lens array according to an exemplary embodiment of the present invention.

[0077] As shown, the desired elliptical shape comprises an elliptical shape **1002**. A circular shape **1004** having a radius can approximate a portion **1005** of the elliptical shape **1002**. Point **1007** indicates an intersection of a tangent **1006** to the ellipse **1004** where the circular shape **1004** exceeds a specified tolerance from the elliptical shape **1002**. A first facet **1008** can be provided beginning at the point **1007** and can approximate a portion of the elliptical shape **1002**. A second facet **1010** can be provided beginning at a point **1009** where the first facet exceeds the specified tolerance from the elliptical shape **1002**. The second facet **1010** can approximate a portion of the elliptical shape **1002** until the desired width  $y$  is reached.

[0078] The tangent **1006**, the first facet **1008**, and the second facet **1010** can form an angle  $l$ ,  $m$ , and  $n$ , respectively, with the major axis **1003** of the elliptical shape **1002**. The actual angles  $l$ ,  $m$ , and  $n$ , the radius  $R$ , and the length of the first and second facets **1008**, **1010** can be determined for a particular application based on the characteristics of the elliptical shape **1002** and the specified tolerance.

[0079] In practice, the radius of the circular shape **1004** can be chosen to approximate a radius  $R$  of the elliptical shape **1002**. Accordingly, the circular shape **1004** can have a radius equal to the radius  $R$  of the elliptical shape. Alternatively, the circular shape **1004** can have a radius different from the radius  $R$  of the elliptical shape, if the different radius can better approximate the elliptical shape. The chosen radius can be used until it exceeds the specified tolerance from the elliptical shape **1002**. The angle  $m$  of the first facet **1008** can be determined based on the elliptical shape **1002** at the tangent point **1007**. Similarly, the angle  $n$  of the second facet **1010** can be determined based on the elliptical shape **1002** at the point **1009**.

[0080] Any number of facets can be used to approximate the elliptical shape **1002**. The number of facets can be adjusted to minimize deviation from the elliptical shape **1002**. For example, using more facets can achieve less deviation from the desired elliptical shape **1002**. In other words, a smaller tolerance limit can be used when more facets are used. Typically, if more facets are used, then a smaller circular portion **1005** can be used to allow a smaller tolerance limit.

[0081] The mitigation of the spherical aberration afforded by the inclusion of the elliptically shaped lens, when compared to conventional lenses, allows the utilization of thinner lenticular lenses to achieve the same or better performance. A common metric used to express the light gathering capability of a lens is known as the focal ratio or F-number ( $F/\#$ ). The focal ratio is simply defined as the ratio of the focal length of the lens divided by the diameter of the lens (specifically the entrance pupil of the lens). The spherical aberration of the conventional lens follows the well-known relationship of being directly proportional to  $1/(F/\#)^3$ . As a conventional lenticular lens is thinned ( $t$  becoming smaller) while maintaining the pitch, it is evident that the image resolution/quality degrades quickly since the  $F/\#$  becomes smaller. For example, the resolution decreases by a factor of over 10 as the  $t$  changes from 0.020 inch to 0.009 inch.

Sheets of thinner lenticular lenses offer significant advantages when affixed to cylindrical objects as explained elsewhere in this specification.

[0082] In an alternative exemplary embodiment, a plurality of facets can be used to approximate the desired elliptical shape without using a circular portion. In one embodiment, corresponding pairs of facets can be used to approximate the desired elliptical shape. In that embodiment, the pseudo elliptical lens elements can have a point where a facet pair meets at the vertex of the lens element. In an alternative embodiment, the vertex can be approximated with a single facet positioned substantially orthogonal to the major axis of the elliptical shape, and corresponding pairs of facets can be used to approximate outer portions of the elliptical shape.

[0083] The tool **1000** can be used to carve a mandrel having a pseudo elliptical shape. The pseudo elliptical mandrel then can be used for casting or extruding lens elements having a pseudo elliptical shape for a lenticular lens array.

[0084] The elliptical shape of the lenticular lens elements according to the exemplary embodiments of the present invention can provide the following benefits over conventional designs: producing less visible print projected aberrations; providing higher printed image contrast; providing thinner gauge lenticular materials that maintain the print quality present in thicker gauge materials (for example, the thinner lenticular materials can be produced with a thickness less than 0.012 inch, and more specifically in the range of about 0.005 inch to about 0.010 inch); providing print images with clearer and smaller serif type and point sizes; providing the thinner lenticular material gauges that can be flexible enough to affix to cylindrical or truncated packaging containers, such as jars, bottles, beverage cups, cartons, etc. without de-laminating off the consumer packaging; providing the thinner lenticular material gauges that can be adaptable to the packaging industry's in-line labeling applicators for rotary roll fed blow down or wipe-down labeling systems; providing the thinner gauge materials that can reduce the thickness and weight per square inch of material, thereby reducing cost; providing increased lenticule viewing width area for broader animated imaging techniques at a lower material thickness and finer lens pitch; or reducing cross-talk and image ghosting.

[0085] The elliptical shape lens elements of the lenticular lens array according to the exemplary embodiments of the present invention can be used in the following printed product types and markets due to the thinner lenticular material possible with the elliptical design: entire outer lenticular packaging enhancements (box overwraps); segmented applied lenticular label coverage to outer packaging; pressure sensitive, non-pressure sensitive, self-adhesive, and non-self-adhesive lenticular label products; multi-ply, multi-substrate peel open pressure sensitive and non-pressure sensitive lenticular labels; lenticular laminated to paper-board products; packaging in-packs and on packs; beverage cups having decorative partial or full lenticular cup wraps; video, dvd, or cd disc cover lenticular treatments; direct mail; magazine inserts; newspaper inserts; or contest and game sweepstake components that comprise use of partial or full lenticular enhancements.

[0086] Although specific embodiments of the present invention have been described above in detail, the descrip-

tion is merely for purposes of illustration. Various modifications of, and equivalent steps corresponding to, the disclosed aspects of the exemplary embodiments, in addition to those described above, can be made by those skilled in the art without departing from the spirit and scope of the present invention defined in the following claims, the scope of which is to be accorded the broadest interpretation so as to encompass such modifications and equivalent structures.

What is claimed is:

**1.** A lenticular lens array for creating a visual effect for an image viewed through said lenticular lens array, comprising:

a plurality of lenticules disposed adjacent to each other to form the lenticular lens array, each lenticule comprising a lenticular lens element on one side and a substantially flat surface on an opposite side,

wherein each lenticular lens element has a vertex and a cross section comprising a portion of an elliptical shape, the elliptical shape comprising a major axis disposed substantially perpendicular to the substantially flat surface of each respective lenticular lens element, and

wherein the vertex of each respective lenticular lens element lies substantially along the major axis of the elliptical shape.

**2.** The lenticular lens array according to claim 1, further comprising an interlaced image printed on the flat surface of at least one of said plurality of lenticules,

wherein viewable portions of said interlaced image change as a viewing angle of said lenticular lens array changes.

**3.** The lenticular lens array according to claim 1, further comprising an interlaced image printed on the flat surface of at least one of said plurality of lenticules,

wherein viewable portions of said interlaced image produce a three-dimensional visual effect when viewed through said lenticular lens array.

**4.** The lenticular lens array according to claim 1, further comprising an opaque substrate, having an interlaced image printed thereon, coupled to the substantially flat surface of said plurality of lenticules,

where the interlaced image printed on said opaque substrate faces the substantially flat surface of at least one of said plurality of lenticules, and

wherein viewable portions of the interlaced image change as a viewing angle of said lenticular lens array changes.

**5.** The lenticular lens array according to claim 1, further comprising a substrate coupled to the substantially flat surface of said plurality of lenticules.

**6.** The lenticular lens array according to claim 5, wherein said plurality of lenticules are cast onto said substrate.

**7.** The lenticular lens array according to claim 6, wherein a discontinuity exists between two adjacent lenticules.

**8.** The lenticular lens array according to claim 1, further comprising a plurality of substrates coupled to the substantially flat surface of said plurality of lenticules.

**9.** The lenticular lens array according to claim 8, wherein one of said plurality of substrates comprises an adhesive layer.

**10.** A lenticular lens array for creating a visual effect for an image viewed through said lenticular lens array, comprising:

a plurality of lenticules disposed adjacent to each other to form the lenticular lens array, each lenticule comprising a lenticular lens element on one side and a substantially flat surface on an opposite side,

wherein each lenticular lens element has a vertex and has a cross section comprising an approximated portion of an elliptical shape, the elliptical shape comprising a major axis disposed substantially perpendicular to the substantially flat surface of each respective lenticular lens element, and

wherein the vertex of each respective lenticular lens element lies substantially along the major axis of the elliptical shape.

**11.** The lenticular lens array according to claim 10, wherein the approximated portion of the elliptical shape comprises:

a circular-shaped portion that approximates a circular-shaped portion of the elliptical shape; and

a plurality of substantially straight portions, each substantially straight portion approximating a portion of the elliptical shape.

**12.** The lenticular lens array according to claim 10, wherein the approximated portion of the elliptical shape comprises:

a circular-shaped portion that approximates a circular-shaped portion of the elliptical shape;

a first pair of corresponding substantially straight portions separately disposed adjacent to opposite ends of the circular-shaped portion and approximating a first portion of the elliptical shape; and

a second pair of corresponding substantially straight portions separately disposed adjacent to a respective one of the first pair of substantially straight portions and approximating a second portion of the elliptical shape.

**13.** The lenticular lens array according to claim 10, wherein the approximated portion of the elliptical shape comprises:

a circular-shaped portion that approximates a circular-shaped portion of the elliptical shape; and

a first substantially straight portion disposed adjacent to the circular-shaped portion and approximating a first portion of the elliptical shape.

**14.** The lenticular lens array according to claim 13, wherein the approximated portion of the elliptical shape further comprises a second substantially straight portion disposed adjacent to the first substantially straight portion and approximating a second portion of the elliptical shape.

**15.** The lenticular lens array according to claim 10, further comprising a substrate coupled to the substantially flat surface of said plurality of lenticules.

**16.** The lenticular lens array according to claim 10, wherein the approximated portion of the elliptical shape comprises a plurality of facets each approximating a portion of the elliptical shape.

17. The lenticular lens array according to claim 16, wherein the plurality of facets comprises a plurality of corresponding pairs of facets.

18. The lenticular lens array according to claim 16, wherein the plurality of facets comprises:

a vertex facet disposed at the vertex of respective lenticular lens elements and positioned substantially orthogonal to the major axis of the elliptical shape; and

a plurality of corresponding pairs of facets disposed outside of said vertex facet.

19. A method for producing a tool, the tool for creating a mandrel for forming elliptically-shaped lens elements of a lenticular lens array, comprising the steps of:

providing a base member having a radius  $b$  corresponding to a minor axis of an elliptical shape, the elliptical shape corresponding to a desired elliptical shape for each lens element of the lenticular lens array; and

cutting the base member along a plane that forms an angle  $k$  with the minor axis of the desired elliptical shape,

wherein the elliptical shape comprises a major axis perpendicular to the minor axis,

wherein a vertex of the desired elliptical shape lies at a point  $a$  along the major axis, and

wherein the angle  $k$  is given by the formula  $\cos(k)=b/a$ .

20. The method according to claim 19, wherein the base member comprises a cylindrical shape.

21. The method according to claim 19, wherein the base member comprises diamond.

22. The method according to claim 19, wherein the radius  $b$  and the point  $a$  are adjusted from the desired elliptical

shape to compensate for a protective surface that will be placed on the mandrel after being created by the tool.

23. The method according to claim 19, wherein the base member comprises a cone shape.

24. A tool for creating a mandrel for forming pseudo elliptically-shaped lens elements of a lenticular lens array, comprising:

a circular-shaped portion that approximates a circular portion of an elliptical shape, the elliptical shape corresponding to a desired elliptical shape for each lens element of the lenticular lens array; and

a plurality of facets disposed adjacent to said circular-shaped portion, each facet approximating a portion of the elliptical shape.

25. The tool according to claim 24, wherein said plurality of facets comprises a first pair of corresponding facets separately disposed on opposite ends of said circular-shaped portion.

26. The tool according to claim 25, wherein said plurality of facets further comprises a second pair of corresponding facets separately disposed adjacent to a respective one of the first pair of corresponding facets.

27. The tool according to claim 24, wherein said circular-shaped portion and said plurality of facets comprise diamond.

28. The tool according to claim 24, wherein the elliptical shape is larger than the desired elliptical shape to compensate for a protective surface that will be placed on the mandrel after being created by said tool.

\* \* \* \* \*